

CUSTOM FLANGED THERMOWELLS

TW Style Straight

- CUSTOM BUILT TO CLIENT DRAWING & SPECIFICATION
- OTHER MATERIALS AVAILABLE: BRASS, HASTELLOY C®, MONEL, ETC.
- STANDARD BORE IS 0.260" & 0.385"

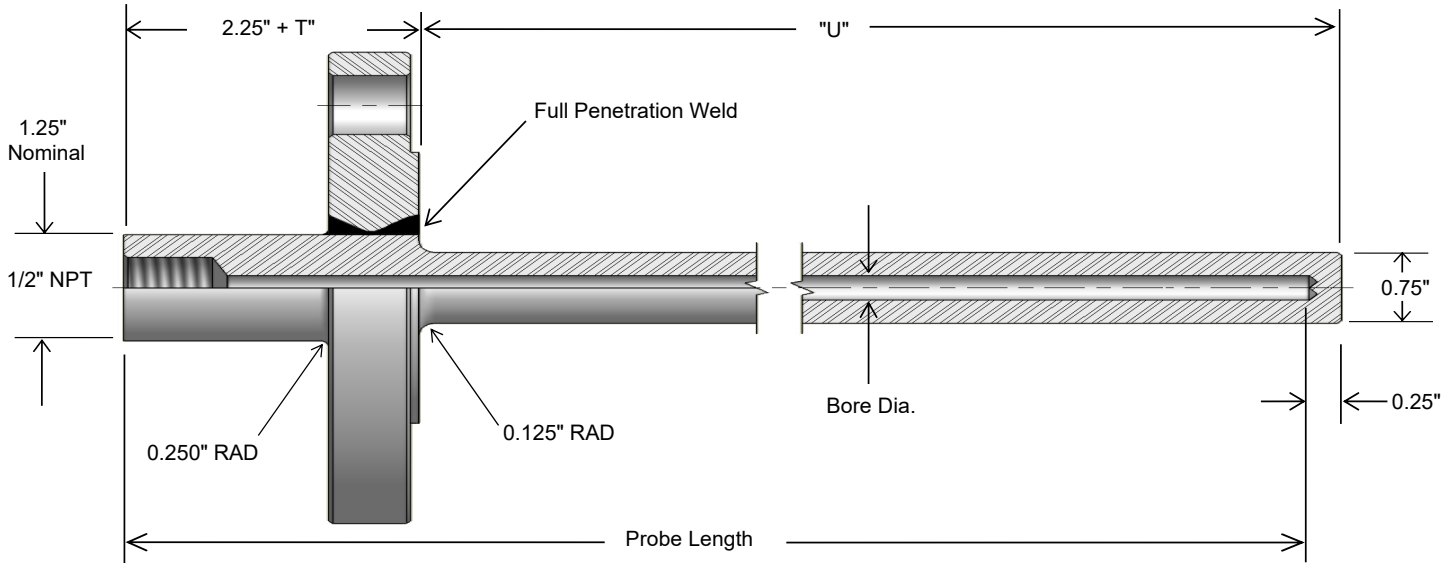

ASSEMBLY NO.

