

IPAQ-L

Universal Programmable 2-wire Transmitters

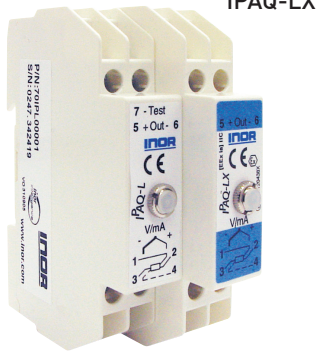

IPAQ-L



IPAQ-L/-LX are universal, isolated 2-wire transmitters for temperature and other measurement applications. They combine competitive pricing, functionality and simple configuration. Useful error correction functions improve the accuracy.

- Fully universal, linearized and isolated
- Accepts RTD, T/C, mV and Ω
- Sensor error and system (sensor/transmitter) error correction for highest total accuracy
- Full access to all features while in operation
- NAMUR compliant
- Consistent sensor break function
- Simplified loop check-up with calibration output
- Test output without breaking the loop (IPAQ-L)
- IPRO, easy-to-use Windows configuration software

Specifications:

Input RTD	3-, 4-wire connection
Pt100 ($\alpha=0.00385$)	-200 to +1000 °C / -328 to +1832 °F
Pt1000 ($\alpha=0.00385$)	-200 to +200 °C / -328 to +392 °F
PtX $10 \leq X \leq 1000$ ($\alpha=0.00385$)	Upper range depending on X-value
Pt100 ($\alpha=0.003902$)	-200 to +1000 °C / -328 to +1832 °F
Pt100 ($\alpha=0.003916$)	-200 to +1000 °C / -328 to +1832 °F
Ni100 ¹⁾ , Ni120 ²⁾	-60 to +250 °C / -76 to +482 °F
Ni1000 ¹⁾	-100 to +150 °C / -148 to +302 °F
Cu10 ³⁾	-200 to +260 °C / -328 to +500 °F
Input Potentiometer/resistance	3-, 4-wire connection. 0 to 2000 Ω
Input Thermocouples	Types B, C, E, J, K, L, N, R, S, T, U
Input mV	-10 to +500 mV
Sensor failure	User definable output
Adjustments-Zero	Any value within range limits
Adjustments-Minimum spans	
Pt100, Pt1000, Ni100, Ni1000	10 °C / 18 °F
Potentiometer	10 Ω
T/C, mV	2 mV
Output	4-20 / 20-4 mA, temperature linear
Operating temperature	-20 to +70 °C / -4 to +158 °F
Galvanic isolation	1500 VAC, 1 min
Power supply	IPAQ-L: 7.5 to 36 VDC IPAQ-LX: 8 to 30 VDC
Intrinsic safety (Mounting in safe area)	
IPAQ-LX ATEX:	II (1) G [Ex ia] IIC
IPAQ-LX FM:	IS Class I-III, DIV 1, GP A-G
IPAQ-LX CSA:	Class I, Groups A-D; Class II, Groups E-G; Class III
Typical accuracy	± 0.1 % of span
Mounting	Rail acc. to DIN EN50022, 35 mm

¹⁾DIN 43760 ²⁾Edison No. 7 ³⁾Edison No. 15

INOR IPAQ-L

Distributor - ThermX Southwest 7370 Opportunity Road, Suite S, San Diego, CA 92111-1414 (800) 284-3769 www.thermx.com

Input connections

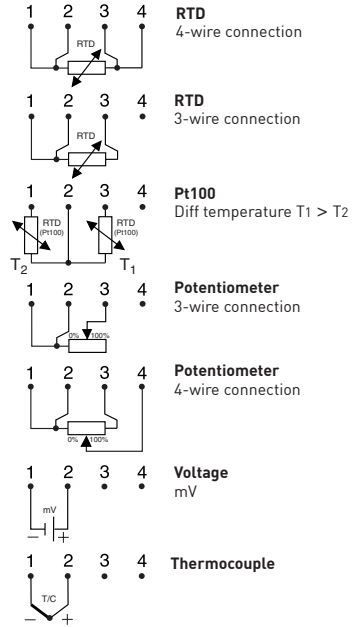

Output connections

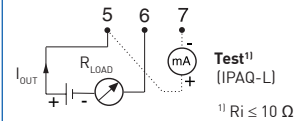

Output load diagram

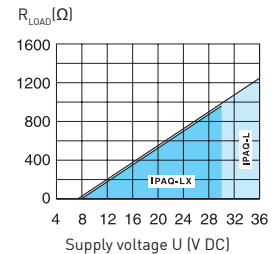

$$R_{LOAD} = (U - 7.5) / 0.022 \text{ (IPAQ-L)}$$

$$R_{LOAD} = (U - 8) / 0.022 \text{ (IPAQ-LX)}$$

Dimensions

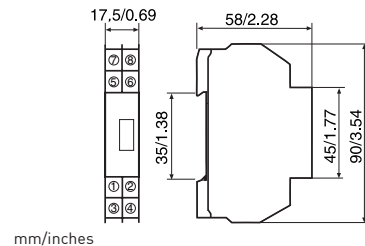

Ordering information

IPAQ-L	70IPL00001
IPAQ-LX (ATEX)	70IPLX0001
IPAQ-LX (FM, CSA)	70IPLX1001
PC Configuration Kit	70CFG00092
Configuration	70CAL00001