

Process transmitter

Model UPT-20, with pressure port

Model UPT-21, with flush diaphragm

WIKA data sheet PE 86.05



Applications

- Process technology
- Machine building and plant construction
- Control technology
- Pharmaceutical industry
- Food industry

Special features

- Multi-functional display
- Simple menu navigation
- Conductive plastic case
- Large LC display, rotatable



Process transmitter, model UPT-20

Description

Instrument construction

The model UPT-2x process transmitter has been developed for applications which require an intelligent sensor. Particularly the integrated temperature compensation makes the process transmitter interesting for a wide range of applications.

The measuring cell is made of stainless steel 316L or of a combination with high-quality Elgiloy®.

The case is rotatable by 330° and the LC display can be mounted in different positions, displaceable in 90° steps. The LC display is easy to read in any mounting position, even from a distance of up to 5 m.

HART® protocol

The process transmitter can be installed both in applications using analogue technique and modern systems communicating via the HART® protocol.

Via the display and operating module or the HART® interface this process transmitter can be configured directly on site.

Turndown

An adjustable turndown (20:1) allows to register exact process values with optimised limits of the measuring values and without major restrictions of the accuracy.

Measuring ranges

Gauge pressure						
bar	0 ... 0.4 0 ... 250	0 ... 1.6 0 ... 600	0 ... 6 0 ... 1,000	0 ... 16	0 ... 40	0 ... 100
psi	0 ... 10 0 ... 1,500	0 ... 15 0 ... 5,000	0 ... 30 0 ... 10,000	0 ... 100	0 ... 300	0 ... 500

1) For model UPT-20: The value specified in the table applies only when sealing is made using a sealing ring below the hexagon. Otherwise max. 1,600 bar applies.

Absolute pressure					
bar	0 ... 0.4	0 ... 1.6	0 ... 6	0 ... 16	0 ... 40
psi	0 ... 30	0 ... 100	0 ... 300	0 ... 500	

Vacuum and +/- measuring ranges						
bar	-0.4 ... 0	-0.2 ... +0.2	-1 ... +0.6	-1 ... +5	-1 ... +15	-1 ... +40
psi	-14.5 ... 0	-14.5 ... +15	-14.5 ... +100	-14.5 ... +300	-14.5 ... +600	

Other measuring ranges can be set via turndown.

For measuring ranges above 600 bar only the model UPT-20 is available.

Vacuum tightness

Vacuum tightness is provided, except for instruments for oxygen applications.

Overpressure limit

Measuring range \leq 16 bar/ 300 psi: 3 times

Measuring range $>$ 16 bar/ 300 psi: 2 times

Accuracy data

Accuracy at reference conditions

Including non-linearity, hysteresis, zero offset and end value deviation (corresponds to measured error per IEC 61298-2).

Accuracy	
Standard	0.15 % of span
Option 1	0.10 % of span
Option 2	0.20 % of span

Mounting correction

-20 ... +20 %

Non-repeatability

\leq 0.1 % of span

Behaviour with turndown (with accuracy 0.15 %)

■ 1:1 ... 5:1 No change in accuracy

■ $>$ 5:1 $<$ 0.03 % x turndown

Long-term stability

\leq (0.1 % x turndown)/year

Thermal change zero point / span (reference temperature 20 °C)

In compensated range 10 ... 70 °C:

$<$ 0.05 % / 10 K x turndown

Outside compensated range:

Typical $<$ 0.1 % / 10 K x turndown

Thermal change of the current output (reference temperature 20 °C)

$<$ 0.05 % / 10 K, max. 0.15 %

Operating conditions

The process pressure transmitter is suitable for internal and external operation. Direct exposure to sunlight is permitted.

Humidity

≤ 93 % r. h.

Ambient temperature

Instrument with display: -20 ... +60 °C

Instrument without display: -40 ... +80 °C ¹⁾

1) Instrument with angular connector or circular connector: -30 ... +80 °C

Storage temperature

-40 ... +80 °C

Medium temperature

Oxygen application: -20 ... +60 °C

Model UPT-20:

-40 ... +85 °C

-40 ... +105 °C at max. 40 °C ambient temperature

-40 ... +120 °C at max. 30 °C ambient temperature

Model UPT-21:

Depending on sealing, cooling element and ambient temperature

UPT-21 without cooling element:

85 °C at max. 80 °C ambient temperature

105 °C at max. 40 °C ambient temperature

120 °C at max. 30 °C ambient temperature

UPT-21 with cooling element:

85 °C at max. 80 °C ambient temperature

120 °C at max. 50 °C ambient temperature

150 °C at max. 40 °C ambient temperature

Sealing	Material	Medium temperature
Standard	NBR	-20 ... +105 °C
Option 1	FKM	-20 ... +105 °C
Option 2	FKM	-20 ... +150 °C ²⁾
Option 3	EPDM ¹⁾	-40 ... +105 °C
Option 4	EPDM ¹⁾	-40 ... +150 °C ²⁾

1) EPDM only with hygienic process connection

2) Process connection with cooling element

Vibration resistance

4 g (5 ... 100 Hz) per GL characteristic curve 2

Shock resistance

150 g (3.2 ms) per IEC 60068-2-27

Ingress protection

IP 66/67

IP 65 for versions with circular connector, angular connector or overvoltage protection

Ingress protection only applies with closed case head and closed cable glands.

Materials

Wetted parts

■ Model UPT-20, measuring range ≤ 40 bar:
Stainless steel 1.4404

■ Model UPT-20, measuring range > 40 bar:
Stainless steel 1.4404 and stainless steel 2.4711

■ Model UPT-21:
Stainless steel 1.4435

Sealing material

See table under Operating conditions, medium temperature

Case

Plastic (PBT) with conductive surfaces to EN 60079-0:2012

Colour: night blue RAL5022

Display and operating unit (option)

Display type

LC display

Refresh rate

200 ms

Main display

4 ½-digit

Additional display

Selectable via menu, three-line scale range

Bargraph display

20-segment, radial, pressure gauge simulation

Colours

Background: light grey

Digits: black

Operating state

Display via symbols

Output signals

Signal	
Standard	4 ... 20 mA
Option	4 ... 20 mA with HART® signal

Load in Ω

$$\leq (U_+ - U_{Bmin}) / 0.023 \text{ A}$$

U_+ = applied power supply (see "Power supply")

U_{Bmin} = minimum power supply (see "Power supply")

Damping

0 ... 99.9 s, adjustable

After the set damping time the instrument outputs 63 % of the applied pressure as output signal.

Settling time t_{90}

60 ms without HART®

80 ms with HART®

Refresh rate

20 ms without HART®

50 ms with HART®

Voltage supply

Power supply U_+

DC 12 ... 36 V

Reference conditions (per IEC 61298-1)

Temperature

23 °C \pm 2 °C

Power supply

DC 23 ... 25 V

Atmospheric pressure

860 ... 1,060 mbar (86 ... 106 kPa, 12.5 ... 15.4 psig)

Humidity

35 ... 95 % r. h.

Characteristic curve determination

Terminal method per IEC 61298-2

Curve characteristics

Linear

Reference mounting position

Vertical, diaphragm points downward

Process connections

With pressure port (for model UPT-20)

In accordance with standard	Thread size	Possible measuring ranges
EN 837	G 3/8 B	$\leq 0 \dots 1,000 \text{ bar}$ $\leq 0 \dots 14,500 \text{ psi}$
	G 1/2 B	$\leq 0 \dots 1,000 \text{ bar}$ $\leq 0 \dots 14,500 \text{ psi}$
	M20 x 1.5	$\leq 0 \dots 1,000 \text{ bar}$ $\leq 0 \dots 14,500 \text{ psi}$
ANSI / ASME B1.20.1	1/2 NPT	$\leq 0 \dots 1,000 \text{ bar}$ $\leq 0 \dots 14,500 \text{ psi}$
	1/2 NPT, female	$\leq 0 \dots 1,000 \text{ bar}$ $\leq 0 \dots 14,500 \text{ psi}$
	1/4 NPT	$\leq 0 \dots 1,000 \text{ bar}$ $\leq 0 \dots 14,500 \text{ psi}$

With flush diaphragm (for model UPT-21)

In accordance with standard	Thread size	Possible measuring ranges
-	G 1/2 B, flush	0 ... 6 up to 0 ... 600 bar 0 ... 50 up to 0 ... 6,000 psi
	G 1 B, flush	$\leq 0 \dots 1.6 \text{ bar}$ $\leq 0 \dots 30 \text{ psi}$
	G 1 1/2 B, flush	$\leq 0 \dots 16 \text{ bar}$ $\leq 0 \dots 30 \text{ psi}$
	G 1 hygienic, flush	$\leq 0 \dots 16 \text{ bar}$ $\leq 0 \dots 30 \text{ psi}$

Pressure transmission medium

Model	Medium
Model UPT-20	Measuring range > 40 bar/500 psi: Synthetic oil, halocarbon oil
	Measuring range \leq 40 bar/500 psi: Dry measuring cell
Model UPT-21	Synthetic oil, halocarbon oil

In general, halocarbon oil for oxygen applications.
Optionally FDA-listed media for the food industry are available.

Diaphragm seals

The model UPT-20 process transmitter can be adapted to the harshest conditions in the process industry by using diaphragm or in-line diaphragm seals. Thus, the transmitter can be used at extreme temperatures and with aggressive, corrosive, heterogeneous, abrasive, highly viscous or toxic media. As a result of the wide variety of aseptic connections (such as clamp, threaded pipe or DIN 11864 aseptic connections) measuring assemblies meet the high demands of sterile process engineering.



Electrical connections

Available connections	Ingress protection	Wire cross-section
Cable gland M20 x 1.5 and spring-loaded terminals	IP 66/67	max. 2.5 mm ² (AWG 14)
Angular connector DIN 175301-803A with mating connector	IP 65	max. 1.5 mm ²
Circular connector M12 x 1 (4-pin) without mating connector	IP 65	-

The stated ingress protection only applies when plugged in using mating connectors that have the appropriate ingress protection.

Electrical safety

Reverse polarity protection

Connection diagrams

Cable gland M20 x 1.5 and spring-loaded terminals

Outlet for connection cable

Pin assignment

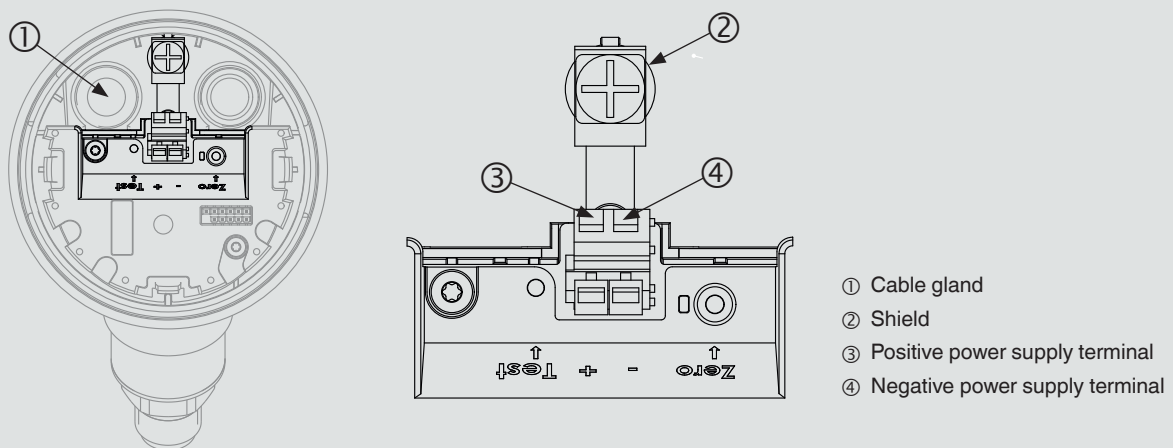

Angular connector DIN 175301-803 A



U ₊	1
U ₋	2
Shield	GND \perp

Circular connector M12 x 1 (4-pin)



U ₊	1
U ₋	3
Shield	4

U₊ Positive power supply terminal
U₋ Negative power supply terminal

CE conformity

Pressure equipment directive

97/23/EC

EMC directive

2004/108/EG interference emission (group 1, class B) and immunity per EN 61326-1:2013 (industrial application), EN 61326-2-3:2013 and per NAMUR NE 21:2011

Dimensions in mm

Process connections for model UPT-20

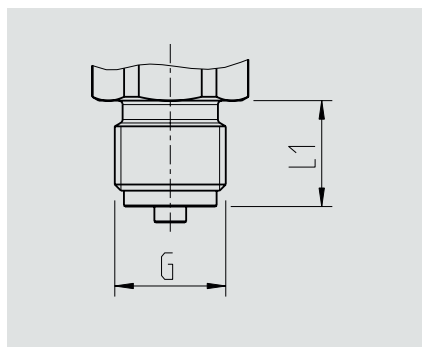

G	L1
G 3/8 B	16
G 1/2 B	20
M20 x 1.5	20

Hexagon dimension: 12 mm

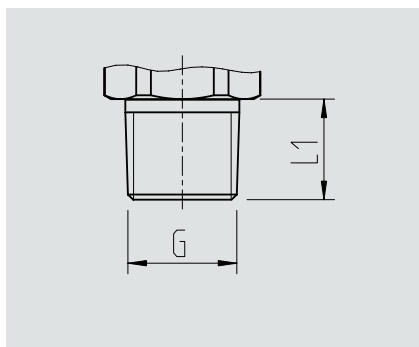

G	L1
1/4 NPT	13
1/2 NPT	19

Hexagon dimension: 12 mm

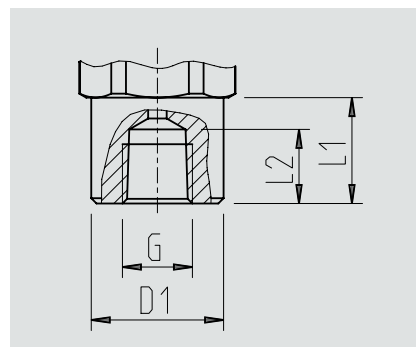

G	L1	L2	D1
1/2 NPT, female	20	19	26.5

Hexagon dimension: 12 mm

Process connections for model UPT-21

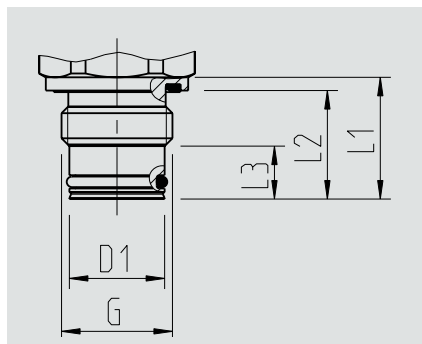

G	L1	L2	L3	D1
G 1/2 B	23	20.5	10	18

Hexagon dimension: 12 mm

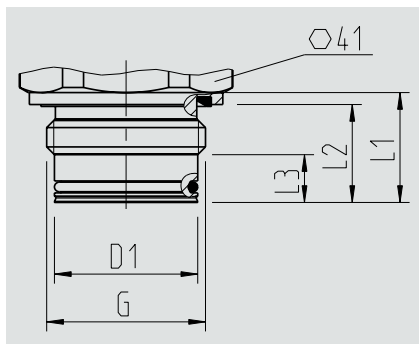

G	L1	L2	L3	D1
G 1 B	23	20.5	10	30

Hexagon dimension: 13 mm

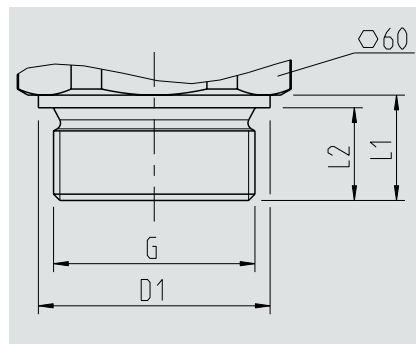

G	L1	L2	D1
G 1 1/2 B	25	22	55

Hexagon dimension: 14 mm

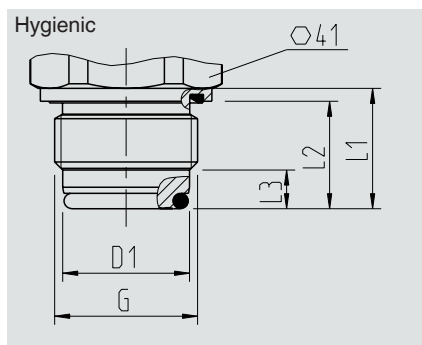

G	L1	L2	L3	D1
G 1 B	28	25	9	29.5

Hexagon dimension: 13 mm

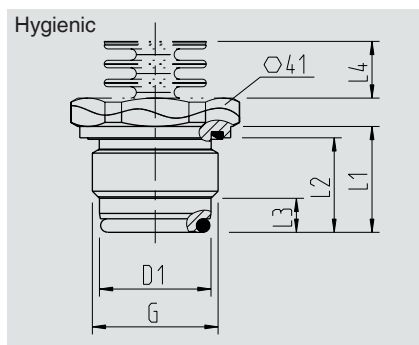





G	L1	L2	L3	L4	D1
G 1 B	28	25	9	15.5	29.5

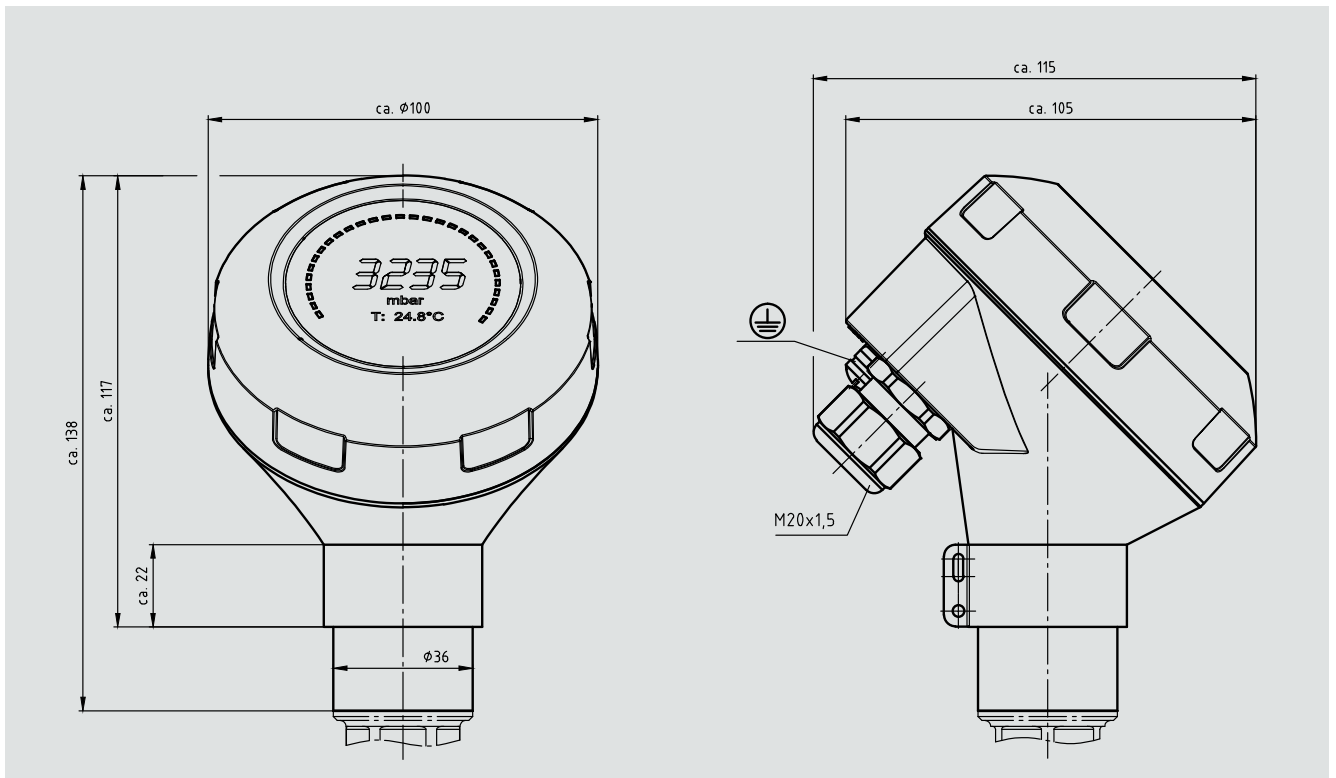



Hexagon dimension: 13 mm

Process transmitter, models UPT-20 and UPT-21



Accessories

	Description	Order no.
	<p>Display module, model DIH52-F 5-digit display, 20-segment bargraph, without separate power supply, with additional HART® functionality. Automatic adjustment of measuring range and span. Secondary-master functionality: Setting the measuring range and unit of the connected transmitter using HART® standard commands possible. Optionally: explosion protection per ATEX</p>	on request
	<p>HART® modem USB interface, model 010031 RS-232 interface, model 010001 Bluetooth® interface [Ex ia] IIC, model 010041</p>	<p>11025166 7957522 11364254</p>
	<p>Hand-held, model FC475HP1EKLUGMT HART® protocol, Li-Ion battery, voltage supply AC 100 ... 240 V, colour display with backlighting, Bluetooth® and infrared interface, ATEX, FM, CSA and IECEx(i) (including FISCO if available)</p> <p>Hand-held, model FC475FP1EKLUGMT HART® protocol and FF Bus, Li-Ion battery, voltage supply AC 100 ... 240 V, colour display with backlighting, Bluetooth® and infrared interface, ATEX, FM, CSA and IECEx(i) (including FISCO if available)</p>	<p>14025585 14025730</p>
	<p>Hand-held, model MFC4150 HART® protocol, universal voltage supply, cable set with 250 Ω resistance, with DOF upgrade, ATEX and cULus</p>	11405333

	Description	Order no.
	<p>Welding socket</p> <ul style="list-style-type: none"> ■ for process connection G ½ flush ■ for process connection G 1 flush ■ for process connection G ½ flush ■ for process connection G 1 hygienic flush 	<p>1192299 1192264 2158982 2166011</p>
	<p>Instrument mounting bracket for wall or pipe mounting, stainless steel</p>	<p>14058660</p>
	<p>Overvoltage protection for transmitters, 4 ... 20 mA, M12 x 1.5, series connection</p>	<p>14002489</p>
	<p>Overvoltage protection, Ex d with flameproof enclosure for transmitters, 4 ... 20 mA, M20 x 1.5</p>	<p>12140503</p>
	<p>Display and operating unit</p> <p>The display and operating unit can be attached in 90° steps. The display and operating unit features a main display and an additional display.</p> <p>The main display shows the output signal. The additional display shows different values, at the same time as the main display - these values can be selected by the user.</p> <p>The process pressure transmitter can be configured through the display and operating unit.</p>	<p>13315277</p>

Ordering information

Model / Measuring range / Output signal / Accuracy / Process connection / Sealing / Electrical connection / Digital indicator / Instrument holder / Overpressure protection / Approval / Certificates

© 2014 WIKA Alexander Wiegand SE & Co. KG, all rights reserved.
The specifications given in this document represent the state of engineering at the time of publishing.
We reserve the right to make modifications to the specifications and materials.