

# Hazardous Area Transmitter for Low Pressure Applications Vapor Recovery, SWD Systems, and Tank Vent Monitoring Type IS-20-VR

WIKA Datasheet IS-20-VR

## Applications

- Vapor recovery control systems
- Salt water disposal control systems
- Tank vent pressure monitoring systems
- Liquid level monitoring in shallow tanks

## Special Features

- Pressure ranges down to 0-12 oz/in<sup>2</sup> with  $\leq 0.25\%$  accuracy
- Low maintenance, non-clogging large diameter pressure port
- NACE MR-01-75 compliant for resistance to sulfide stress cracking
- FM and CSA approved for installation Class I, Division 1 hazardous areas
- Engineered to meet the harsh demands of upstream vapor recovery, SWD, and tank vent monitoring systems

## Description

As environmental regulations to reduce fugitive emissions become more stringent and complex, accurate and reliable monitoring of low pressures is increasing in importance.

Vapor recovery systems, salt water disposal systems, and storage tank pressure monitoring require accurate, consistent pressure measurement for optimal performance of the control and monitoring systems.

The WIKA IS-20-VR low pressure transmitter is designed for use in hazardous area applications requiring extremely low pressure ranges measured in ounces per square inch.

The IS-20-VR features an industry standard 4-20 mA output and FM intrinsically safe approvals for installation in class I Division 1 locations.



IS-20-VR pressure transmitter

The IS-20-VR can also be used for liquid level monitoring down to 0-20 inches water column (0-12 oz/in<sup>2</sup>) and is sensitive enough to detect level changes as small as  $\pm 0.05$  inches.



The  $\frac{1}{2}$  NPT male process connection features a large pressure port for improved resistance against obstruction by particulates, scale, or media buildup.

# Specifications

# Model IS-20-VR

Pressure Range	Maximum	Burst
0 ... 12 oz/in <sup>2</sup>	240 oz/in <sup>2</sup> (15 psi)	320 oz/in <sup>2</sup> (20 psi)
- 4 ... 0 ... 12 oz/in <sup>2</sup>		
0 ... 16 oz/in <sup>2</sup>		
FM, CSA Approvals		FM standards according to FMRC 3600, 3610, 3611 (including supplement #1), ISA-S12.0.01, IEC 60 529 (including amendment #1) CSA standard C22.2 No. 0-M1991 / 142-M1987 / 157-M1992 UL 50, Eleventh Edition / UL 508, Seventeenth Edition / UL 913, Sixth Edition
HF-immunity	V/m	10
Burst	KV	2
Accuracy <sup>1)</sup>	% of span	≤ 0.25 (BFSL)
	% of span	≤ 0.5 (limit point calibration)
Non-repeatability	% of span	≤ 0.05
1-year stability	% of span	≤ 0.2
Compensated temperature range		32 ... +176°F (0 ... +80°C)
TC within compensated range	% of span	≤ 0.8 / 10K
Zero and span		Non-adjustable
Wiring protection		Protected against reverse polarity and short circuit
Ignition protection type	FM, CSA	Class I, II and III
		Intrinsically safe Class I, II, III Division 1, Groups A, B, C, D, E, F, G and Class I, Zone 0 AEx ia II C

1.) Including linearity, hysteresis and repeatability. Limit point Calibration performed in vertical mounting position with pressure connection facing down. Transmitter should be mounted in vertical position with pressure connection facing down for best performance.

Note: additional specifications are available on data sheet IS-20. Options listed on the IS-20 data sheet are not available on the IS-20-VR version.



IS-20-VR installed on salt water disposal system tank

### Wiring

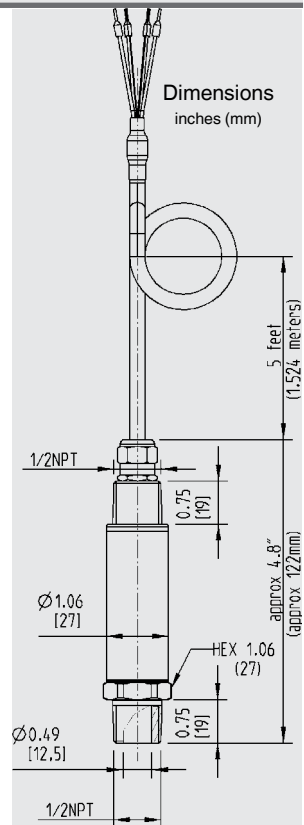
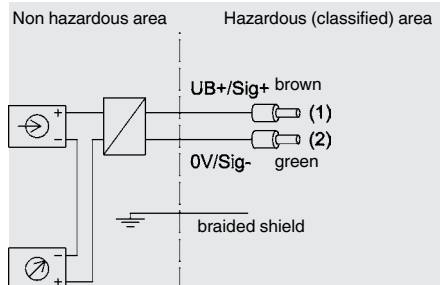

Specifications and dimensions given in this datasheet represent the state of engineering at the time of printing. Modifications may take place and materials specified may be replaced by others without prior notice.



**WIKA Instrument Corporation**  
1000 Wiegand Boulevard  
Lawrenceville, GA 30043-5868

WIKA IS-20-VR  
Distributor  
ThermX Southwest  
7370 Opportunity Road, Suite S  
San Diego, CA 92111-1414  
(800) 284-3769  
www.thermx.com